

Extreme Material-Handling Challenges - Require **EXTREME** Components!

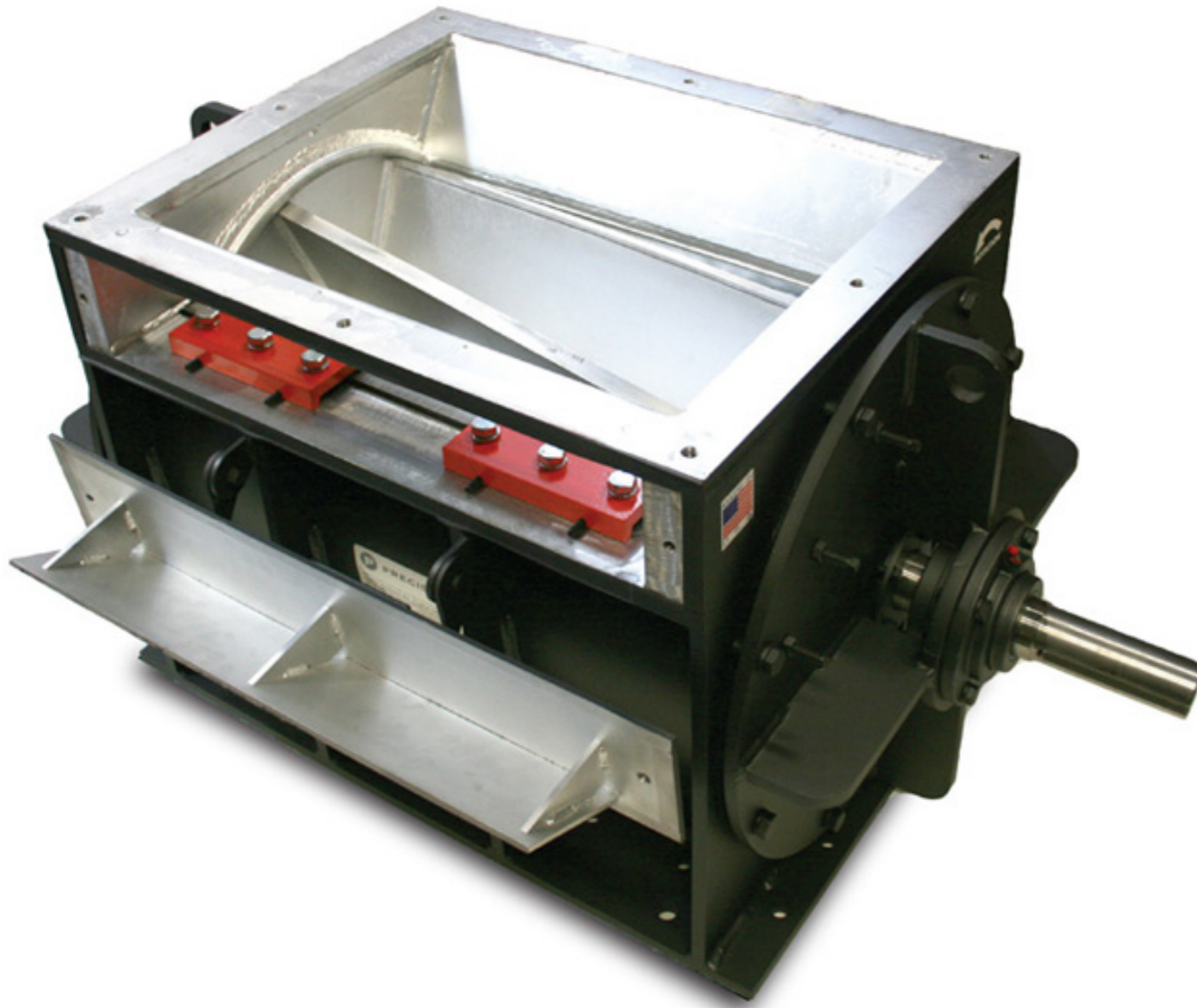

**PRECISION**  
MACHINE & MANUFACTURING

## HEAVY-DUTY ROTARY FEEDER



Wood, Biofuel, Pulp &  
Paper, Organics, Rubber,  
Alternative Fuels-

*One Rotary Feeder  
does it all!*

 [premach.com](http://premach.com)

**"Superior return on Investment"**



**Rotary Feeders • Rotary Valves • Screw Conveyors**



**Durable.  
Reliable.  
Adaptable.**

Precision's Rotary Feeder is a step above the competition! Whether your material handling system is running wood, chips, pulp, alternative fuels or other types of organic material, the hardened tool steel knife ensures that only uniform sized material is being introduced into the system. An airlock and a metering device all in one!

## HEAVY-DUTY ROTARY FEEDER What Makes the Rotary Feeder Work

### Rotor

An 8-pocket helical rotor vane arrangement creates a scissoring action to shear off large and/or irregular pieces, which minimizes feeder jamming.

### Hardened Steel Knife

Each Rotary Feeder is equipped with a special USA sourced hardened tool steel knife, which is adjustable to maintain optimal clearance. The knife along with the shearing action of a helical rotor ensures that only consistently sized material is being fed into the system.

### Access

Access door provides easy access to inspect clearances and provide adjustment.

### Upgrades & Accessories

A variety of upgradeable options exist so your new feeder is perfectly equipped for your specific application.

6

### Surface Hardened

Depending upon the size, optional surface hardening is available to provide additional abrasion resistance!

### HD Bearings

Equipped with high load outboard tapered roller bearings, which are heavy-duty, industrial grade to ensure proper shaft alignment.

### Focused Industries



### Rebuildable!

The only truly rebuildable rotary feeder in the industry! Built for outage to outage functionality. Minimal maintenance ensures this unit meets your expectations! Rebuild, Refresh and Reuse!

### Application Specific

Every Rotor and Barrel are perfectly mated up to meet the specifications of the application. Precisely machined to operate within the specified temperature and at the optimum throughput.

**Rugged  
Durability**

Simply put, **Rugged Durability** means **Made in the USA!** Every rotary feeder is built with domestically sourced materials and are manufactured right here in America at our home office in Eugene, Oregon. Here at **Precision Machine & Manufacturing**, we employ hard working Americans who not only take great pride in building the highest quality rotary feeders available but are also personally active within their respective communities. Within our business, we have youth coaches, volunteer firemen, civic leaders, and veterans to name a few. Every rotary feeder leaving our facility was built by people who epitomize what **Rugged Durability** really means!

**Maximize throughput,  
improve material flow,  
decrease "blow-by,"  
and eliminate  
unplanned downtime!**

## HEAVY-DUTY ROTARY FEEDERS Key Advantages

- ✓ Wear resistance is built into every heavy-duty rotary feeder! Our goal is to eliminate unplanned downtime and achieve an operational life of at least one year (minimum) for the most abrasive products and up to seven+ years for less abrasive materials.
- ✓ One rotary feeder that literally can do it all! Whether the material is organic such as wood, pulp, and biofuels or consist of materials such as rubber and/or alternative fuels, PMM's rotary feeder is the preferred option for material handling systems moving these types of materials.
- ✓ Upgradeable! A variety of options, upgrades and surface treatments are available to ensure each rotary feeder being put into operation is precisely equipped to achieve the required throughput.
- ✓ Rebuildable- A major difference between Precision's rotary feeders and the competition, is that we encourage returning the feeder to factory specifications by rebuilding it. Most PMM rotary feeders can be rebuilt for about 75% the cost of new and they come with a brand-new factory warranty! Refresh, Rebuild and Reuse!
- ✓ Eliminate Blow-By! Rotors are precisely machined to match up with the feeder's housing. This keeps air bypass to a minimum and ensures the material flows as intended.

Precision Machine & Manufacturing's components are precisely crafted from raw materials that are made right here in the United States of America!  
**Quality you can count on!**



**P** [premach.com](http://premach.com)

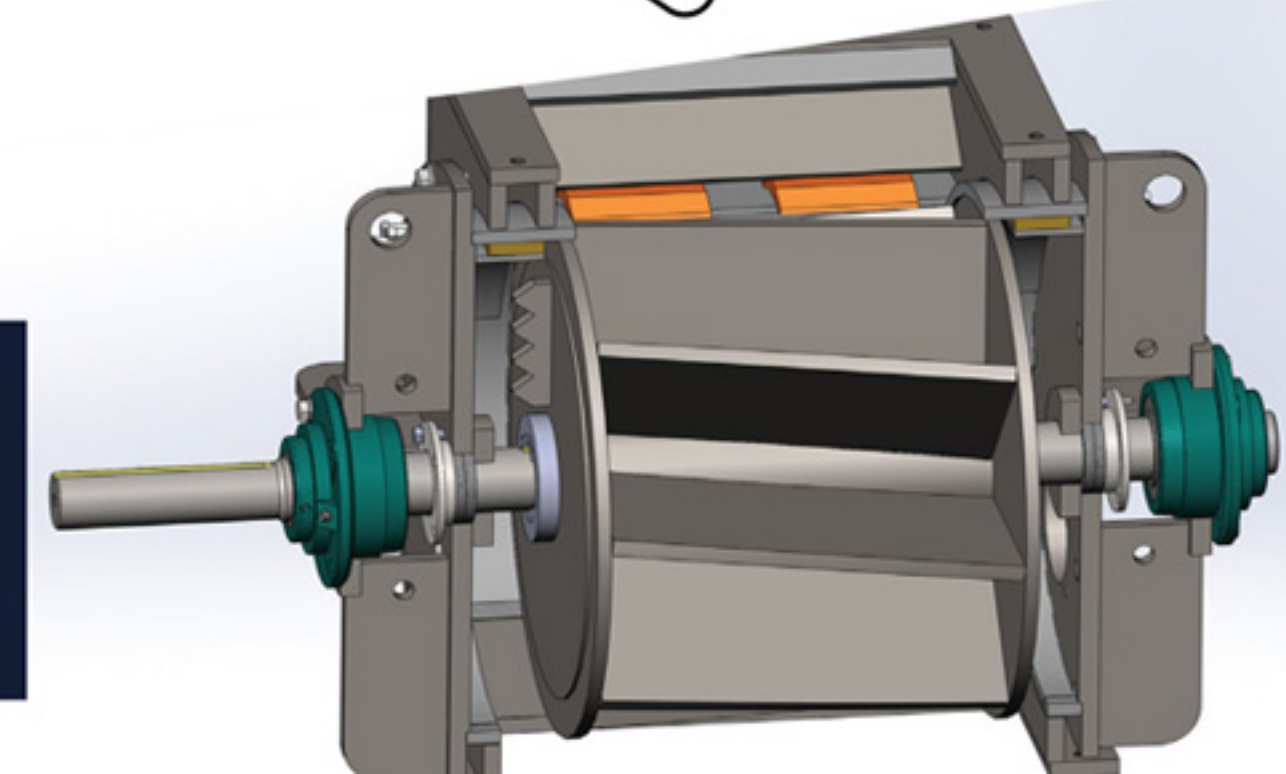

Choose the right size for your unique material handling application.

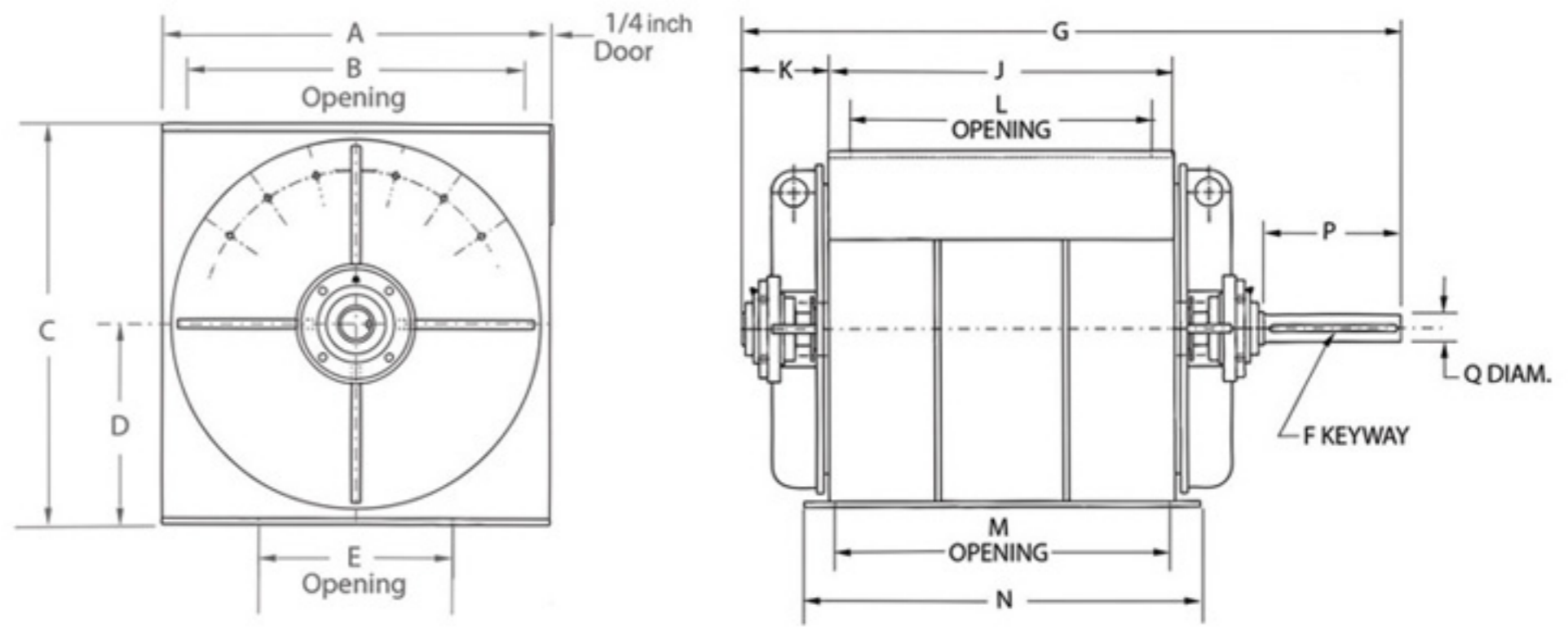

CAPACITIES & DIMENSIONS		*Cubic Feet Per Revolution														
Size	*CFR	A	B	C	D	E	F	G	J	K	L	M	N	P	Q	
PMR-14X18	0.93	18.00	15.00	18.00	9.00	9.00	1/2 X 1/4 X 7-1/4	44.0000	19.25	9.1900	15.00	18.00	22.00	8.3800	1 15/16	
PMR-16X20	1.46	20.00	16.00	21.00	10.50	10.00	1/2 X 1/4 X 6 7/16	43.8125	21.00	8.0625	16.50	20.00	24.00	6.8125	1 15/16	
PMR-20X20	2.19	25.00	21.00	26.00	13.00	13.00	1/2 X 1/4 X 7 5/8	44.0625	21.00	7.5625	16.00	20.00	25.00	7.9375	2 3/16	
PMR-20X25	2.93	25.00	21.00	26.00	13.00	13.00	5/8 X 1/4 X 7 5/8	49.0625	26.00	7.6875	21.00	25.00	30.00	8.9375	2 7/16	
PMR-20X30	3.66	25.00	21.00	26.00	13.00	13.00	1/2 X 1/4 X 7 5/8	54.3125	31.00	7.6875	26.00	30.00	35.50	7.9375	2 3/16	
PMR-25X30	5.65	31.00	27.00	32.00	16.00	16.00	5/8 X 5/16 X 10	58.1250	31.00	8.3750	27.00	30.00	35.50	10.3750	2 7/16	
PMR-25X35	6.78	31.00	27.00	32.00	16.00	16.00	3/4 X 3/8 X 10	63.3750	36.00	8.5000	31.00	35.00	40.50	10.3750	2 7/16	
PMR-30X30	8.45	38.00	34.00	38.00	19.00	18.00	3/4 X 3/8 X 9 15/16	59.5000	31.00	9.0625	26.00	30.00	38.00	10.3750	2 15/16	
PMR-30X35	10.30	38.00	34.00	38.00	19.00	18.00	3/4 X 3/8 X 10 3/4	65.3125	36.00	9.0625	31.00	35.00	43.00	11.1875	2 15/16	
PMR-30X40	11.10	38.00	34.00	38.00	19.00	18.00	3/4 X 5/16 X 10 3/4	69.7500	41.00	8.8125	35.00	40.00	47.00	11.1875	2 15/16	
PMR-30X45	12.70	38.00	34.00	38.00	19.00	18.00	7/8 X 7/16 X 12 3/4	77.0625	46.00	9.0625	40.00	45.00	52.00	13.4375	3 7/16	
PMR-35X45	17.20	44.00	36.00	44.00	22.00	22.75	1 X 1/2 X 12 11/16	82.6250	49.00	10.3125	41.75	47.75	55.25	13.5000	3 15/16	
PMR-35X50	19.35	44.00	36.00	44.00	22.00	22.75	1 X 1/2 X 12 11/16	87.6250	54.00	10.3125	46.75	52.50	60.25	13.5000	3 15/16	
PMR-35X55	21.50	44.00	36.00	44.00	22.00	22.75	1 X 1/2 X 12 11/16	91.6250	58.00	10.3125	52.00	56.75	65.75	13.5000	3 15/16	
PMR-45X45	30.00	56.00	46.00	56.00	28.00	32.00	1 X 1/2 X 12 11/16	89.7500	49.00	13.6250	41.75	47.00	55.25	13.5625	3 15/16	
PMR-45X50	33.75	56.00	46.00	56.00	28.00	32.00	1 X 1/2 X 15 3/16	95.9375	53.00	13.6250	47.00	51.25	60.50	15.7500	4 7/16	
PMR-45X55	37.50	56.00	46.00	56.00	28.00	32.00	1 X 1/2 X 12 11/16	98.1875	58.25	13.3750	52.25	56.50	65.50	13.2500	3 15/16	

### REBUILDABLE

Built to provide long lasting durability and a return on investment for many years to come. PMM's Rotary Feeders are all completely rebuildable and come with a new manufacturer's warranty.

### UPGRADEABLE

PMM's Rotary Feeders come with a variety of upgrades, options, and surface treatments to ensure a precisely equipped material metering air lock is put into your operation.

**CONTACT  
PRECISION  
TODAY**

For more information.

**541-484-9841**  
**sales@premach.com**



**PRECISION**  
MACHINE & MANUFACTURING

1290 S. Bertelsen Road, Eugene, OR 97402

 **premach.com**

